

ARTICULO: 2228

Válvula de Equilibrado estático - Orificio Variable - Doble Regulación Balancing Valves - Variable orifice - Double Regulating

Características

1. Válvula de globo de doble regulación y orificio variable según norma BS 7350.
2. Destinada a regular y equilibrar el caudal en instalaciones de calefacción y refrigeración con alta precisión, lo que implica una distribución más uniforme de la temperatura.
3. Cuerpo y Bonete contruidos de F. Dúctil.
4. Bridas PN16 según EN 1092.
5. Longitud entre caras según EN 558-1 serie 1.
6. Eje no ascendente. Diseño compacto.
7. Disco recubierto en EPDM.
8. Provista con tapones para verificación (Rc 1/4").
9. El volante cuenta con indicador de posición y limitador de carrera (preset) para memorizar una posición determinada de apertura.
10. Triple función: Medición, Regulación y Corte.
11. Presión de trabajo máxima 16 bar.
12. No requiere mantenimiento.

Condiciones de trabajo:

- Agua: -10°C a +120°C
(bajo 0°C solamente para agua + glicol)

Features

1. Variable orifice cast iron double regulating globe valve according to BS 7350 standard.
2. Designed to regulate and balance the flow in heating and cooling with high precision, which means a more uniform temperature distribution.
3. Body and Bonnet in Ductil Iron.
4. PN16 flanges according to EN 1092.
5. Face To Face according to EN558-1 series 1.
6. Non rising stem. Compact design.
7. EPDM coated disk.
8. Provided with test points (Rc 1/4").
9. Handwheel with position indicator and preset screw to store a given open position.
10. Three functions: Measuring, Regulating and Isolating.
11. Max. working pressure 16 bar.
12. No maintenance.

Working conditions:

- Water: -10°C to +120°C
(below 0°C only for water + glycol)

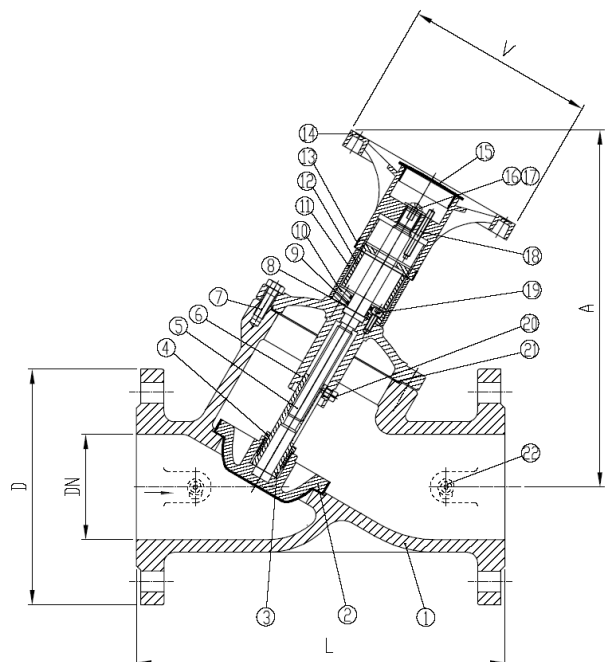

Nº	Denominación / Name	Material	Acabado Superficial / Surface Treatment
1	Cuerpo / Body	ASTM A536 65-45-12	Pintado / Painted
2	Disco / Disc	ASTM A126 B + EPDM	-----
3	Tuerca Eje / Stem Nut	Aleación de cobre / Cooper Alloy	-----
4	Unión Disco / Disc Cover	Latón / Brass	-----
5	Eje / Stem	ASTM A276 420	-----
6	Bonete / Bonnet	ASTM A536 65-45-12	Pintado / Painted
7	Tornillo / Bolt	Acero al Carbono / Carbon Steel	Pintado / Painted
8	O-ring	EPDM	-----
9	O-ring	EPDM	-----
10	Brida prensa / Gland Flange	ASTM A536 65-45-12	Niquelado / Ni plated
11	Tapa / Link Cover	Plástico alta resistencia / ABS	-----
12	Tapa Guía / Direction Cover	Plástico alta resistencia / ABS	-----
13	Anillo Indicador / Scale Ring	Plástico / Black Plastic	-----
14	Volante / Handwheel	Aluminium	Pintado / Painted
15	Tapa / Cover	Poliétileno / PE	-----
16	Tornillo / Screw	ASTM A276 420	-----
17	Arandela / Washer	ASTM A276 420	-----
18	Espárrago / Locating Screw	AISI 1035	Zincado / Zn plated
19	Tornillo / Screw	Acero al Carbono / Carbon Steel	Zincado / Zn plated
20	Tornillo Guía / Screw	ASTM A276 420	-----
21	Junta / Gasket	EPDM	-----
22	Tapón / Plug	Latón / Brass	-----

DIMENSIONES GENERALES / GENERAL DIMENSIONS

Ref.	Medida / Size	DN	Dimensiones / Dimensions (mm)				Peso / Weight (Kg)
			D	L	A	V	
2228 09	2"	50	165	230	276	180	12,800
2228 10	2 ½"	65	185	290	308	180	18,900
2228 11	3"	80	200	310	320	180	23,500
2228 12	4"	100	220	350	340	180	32,200
2228 13	5"	125	250	400	375	240	50,600
2228 14	6"	150	285	480	410	240	68,200
2228 16	8"	200	340	600	550	350	128,000
2228 18	10"	250	405	730	590	350	206,000
2228 20	12"	300	460	850	678	450	307,500

TABLA DE CAUDALES / FLOW MEASUREMENT

Posición Volante / Handwheel Position	Kv (m ³ /h @ 1 bar)								
	DN 50	DN 65	DN 80	DN 100	DN 125	DN 150	DN 200	DN 250	DN 300
1	6.9	14.5	18.5	37.2	64.3	89.6	87.3	113.4	163.4
2	12.2	27.5	32.7	69.4	104.4	146.3	160.6	173.5	295.3
3	18.3	40.5	50.8	102.5	150.5	213.4	240.5	241.8	455.5
4	25.5	53.2	71.8	133.5	196.7	275.6	331.4	318.5	643.5
5	33.9	64.4	89.7	163.4	241.5	338.4	420.3	413.4	852.4
6	40.2	73.4	107.3	189.6	280.4	404.5	498.5	523.5	1037.6
7	44.4	81.6	118.8	213.5	309.5	448.6	573.6	630.6	1197.8
8	47.3	86.6	131.2	230.4	331.3	478.2	641.4	727.8	1384.8
9	----	----	----	----	----	----	704.6	819.6	1568.1
10	----	----	----	----	----	----	764.5	918.1	1739.0
11	----	----	----	----	----	----	811.9	1018.2	1919.4
12	----	----	----	----	----	----	865.6	1116.3	2099.4

* valores de caudal con las siguientes tolerancias: $\pm 18\%$ (válvula abierta al 25%) y $\pm 10\%$ (válvula abierta totalmente), según norma BS 7350.

* flow rate within the following tolerances: $\pm 18\%$ (at the 25% open position) and $\pm 10\%$ (at the fully open position), according to BS 7350 standard.

